

Development of Floor Tile Power Generating Light Up LED

Imanina Zakirah Saifudin¹ & Mohd Izhar A Bakar²

^{1,2}Electrical Technology Section,
Universiti Kuala Lumpur British Malaysian Institute
Batu 8, Jalan Sungai Pusu
53100 Gombak Selangor, Malaysia

Corresponding email: mizhar@unikl.edu.my

Abstract: Human has become increasingly reliant on technology, particularly electronic devices, over the last century. All electronic devices require power and currently worldwide facing the issue was continued depletion of fossil energy. This study will be discussing on harnessing the energy harvesting system via pressure. The main goal of this project is to show the concept of generating electricity from human footsteps using the concept of converting mechanical strain energy into electrical energy. Energy harvesting paves the way to pervasive, totally autonomous self-powered systems that do not require human involvement for energy replenishment. This project uses Piezoelectric (PZT) which produced energy when pressed. It also has an Arduino as a controller and a Blynk application to monitor how much energy is produced via smartphone. As a result, this initiative is both cost-effective and simple to implement, and it is one of the most promising approaches to solving the worldwide problem without diminishing natural resources.

Keywords: Arduino Uno, Piezoelectric Sensor, Footsteps, Energy Harvesting System

1.0 INTRODUCTION

Malaysia's economy has grown at breakneck speed due to its reliance on energy. Malaysia's reliance on the energy sector will grow in lockstep as the country moves closer to being an industrialized nation. The growth and development of Malaysia continued to contribute towards the Industrial Revolution (IR 4.0). From the scenario that happens in Malaysia and around the world, it gives the idea to use human footsteps to generate energy as it is harmless to the environment and walking is the most common activity every day. Generating energy using human steps uses the concept of kinetic energy which generates energy when a person walks. This condition will use PZT technology as it can transfer energy into electrical energy. The PZT sensor has the sufficiency to generate electrical energy from foot stress. The higher the number of people walking in that area, the higher the number of powers generate. This project can be installed in the walkway area.

2.0 LITERATURE REVIEW

According to Poddar et al. (2017), the PZT effect is a notion in which a PZT material can build up an electrical charge by applying pressure and strain to it. This project investigates the use of PZT sensors in both configurations which are a series and parallel. Their testing revealed that the connection

is good in series, but the current obtained is poor, whereas the current is good in parallel, but the voltage is poor. It employed a Liquid Crystal Display (LCD) to display the voltage created across the piezo tile. The LCD was controlled by a Peripheral Interface Controller (PIC). To conclude this article, the weight of the human body will affect the power produced by piezo tile and is suited to implementation in crowded areas [1].

Based on research conducted by Niyeditha et al. (2020), power generation and its usage are one of the issues. The number of power sources present, non-renewable & renewable still cannot overcome the demand. This project will generate power by walking or running [2]. The project's goal is to convert weight energy into electrical energy. This project used the PZT effect to convert mechanical stress to electrical energy. When applying electricity to a PZT material, it will compress or stretch the PZT material. This project uses Arduino Uno as a controller to connect the PZT sensor to an LCD. An inverter was used to convert the Alternating Current (AC) output produced by piezo to Direct Current (DC) as it has a battery to store the generated power. Therefore, this article was used as a reference for using Arduino Uno as its microcontroller.

As written by Putri Norlyana Mustafa Kamal (2018), this article shows the result of its preliminary investigation to evaluate the possibility of using PZT elements to harvest energy from footsteps. Based on this research paper, the output current and voltage is not dependent on the number of PZT sensors, but it depends on the type of connection. In series, the voltage is increased, in parallel, the current is increased while in series-parallel connection, it can balance the increasing output value for voltage and current. The connection of the circuit depends on the purpose of the output power to be used [3].

Bokjja, P. et al (2015) conducted a project on the design and development of footsteps-based energy for streetlights. The objective of this project is to generate energy through the pressure generated by footsteps. It used a microcontroller and was placed at the bottom of the floor tiles. The pressure generated is connected to the microcontroller to send the signal converted to electrical energy and stored in the battery. This energy storage can be used to power up streetlights at night automatically without human intervention. Therefore, this project helps with the current crisis of energy by innovating technology that can develop extra energy without wasting other resources [4]. A lot of wasted energy is due to the inefficiency of the system where the streetlight does not switch off when nobody passes that runway.

According to Abdi, P.B. et al (2018), the demand for sustainable green energy is increasing, but the supply of energy is not catching up. Footsteps are one of the most rapid actions that humans engage in. Every footstep action creates tremendous amounts of kinetic energy in terms of pressure force at diverse locations. As an alternative energy source that has yet to be completely tapped, these human steps can be used to power some low-voltage loads. A tile with PZT transducers is designed and implemented in this study to generate electrical pulses while also gathering the energy of human footsteps. In this study, lead zirconate titanate PZT transducers were used. The PZT floor energy harvester system can generate an AC voltage of up to 71.20 V from a tile made up of 20 parallel connected PZT transducers. The average voltage generated is 63.98 V [5]. As a result, the average power of each step is 0.0604 watts [5]. The author infers that by arranging this PZT generator with some tiles, it may generate more power and harvest this energy more efficiently.

Mota, J. et al (2018) research paper stated that the idea of PZTity is used to collect data about pedestrians such as movement patterns and tracking by harvesting energy from their footsteps. This data on pedestrian movement patterns can be utilized to make decisions on how to build a floor plan based on the location where it will be located. This project's energy can be used to power lamps, and public Wi-Fi and contribute to the generation of more renewable

energy, as non-renewable energy prices are falling and it may not always be possible to harness solar, wind, and hydropower [6]. In comparison to other natural and synthetic crystals, this study utilized PZT crystals because it has a strong PZT effect, resistance to dampness, and high material strength. The outcome of this analysis is it uses an Arduino controller to support the data. All the voltage measurement for the tiles is collected continuously and stored in a Comma Separated Value (CSV) file to be used for analysis purposes.

2.7-FOOT STEP POWER GENERATION

Vinayak, M.N. et al (2016) research paper focuses on how much energy is generated by climbing stairs. The use of stairs in every building is increasing every day even in a small building. The energy dissipated on a floor must be transformed into usable energy by applying the principle of the PZT effect. The energy generated can be used for residential purposes. This system can be installed at homes, schools, and institutions where people constantly pass through. This project will have a control mechanism that carries a PZT sensor, and it will activate when there are vibrations, tension, or straining forces exerted by the foot on the platform. The sensor is connected to a booster, which boosts the output of the PZT and sends it to the battery through the unidirectional current controller and an AC ripple neutralizer. The output of the battery is connected to an inverter, which converts DC into AC to be used by various applications [7]. Microcontroller AT8952 is used to display the generated power by using an LCD.

Based on research conducted by Srivastava, R. et al (2015), natural resources will run out one day. Energy harvesting is one of nature's energy sources. Energy harvesting is defined as collecting minute quantities of energy from one or more of the surrounding energy sources. The energy that comes from natural sources is termed renewable energy. This project discussed generating micro-energy from vibration and pressure using PZT material. The advantage of PZT is it has a very high-frequency response, and self-generating, is simple to use, and has a large dielectric constant. This floor tile can generate a minimum of 1V per step and a maximum of 10.5V per step by using the 12 piezo sensors connecting in parallel [8].

According to Mugali, S. et al. (2018) power generation is the single largest source of population in the globe. The human population keeps increasing raising worry about the supply of power. This project investigates on use of PZT materials to harvest energy from people walking vibration for generating and accumulating the energy [9]. When the flooring is designed using PZT technology, the electricity generated can be converted to electrically charged by a piezo-electric transducer. It has a microcontroller to monitor the voltage and charges a battery. The footstep board

consists of 15 PZT sensors which are connected in parallel [9]. When the pressure is applied, it will charge a 12V DC rechargeable battery. An inverter is used to convert the 12V DC to 230V AC to operate on AC loads.

Raju, K. et al (2020) research paper proposed a power generation technique through the piezo sensor. This paper discussed designing the ground surface with PZT innovation where the electrical vitality created by the weight is captured by the floor sensor. Then it converts to electrical charge by using the PZT transducer [10]. This project uses Arduino as a controller and connects with a bridge rectifier to stabilize the output then charges a DC battery. The output voltage produced will be displayed using Liquid Crystal Oscillator (LCO) while the status of battery charging can be seen by the user using a mobile phone via a GSM modem. The power created can be used in numerous applications, especially in a place where there is no electricity provided.

Based on research conducted by Ali, A. et al (2020) the generation of power using footsteps is one of the several methods of generating renewable energy resources. The PZT effect can produce an electric charge in response to applied pressure. This project uses four PZT sensors connected in series which are also connected with a complex circuit that contained 7805 voltage regulator IC, IN4007 diodes, boost converter, etc. This energy can be generated when walking on certain arrangements such as walkways, stairs, stations, and so on, as well as in any densely populated area for maximum efficiency [11]. There are a few methods of testing the sensitivity of PZT sensors which are bending, compression, and, shear mode sensors. The highest sensitivity is in bending mode. This project used Light Emitting Diode (LED) to indicate the electricity produced by applying force while the capacitor is used to retain the glow of electricity. 7805 voltage regulator IC is used for the charging purpose to allow the voltage flow in the accepted range of mobile phones.

According to Sahoo, G. et al (2016), the amount of generated electrical energy is insufficient to meet demand. Alternative sources are being explored to prepare for the future dearth of traditional energy sources [12]. The main aim of this research paper is to automate the street light system by using the PZT material paced on the road [12]. The piezoelectricity from piezo is AC in nature and then it is rectified to get DC output voltage. The regulator and booster are used to make the project more practical to charge the 12V battery. Arduino Uno acts as a controller to control Light Dependent Resistor (LDR) to determine whether it is daytime or nighttime and to detect the presence of a vehicle to power LED in the dark. Therefore, it will save energy.

Chavan, A. et al (2017) research paper stated that power generation using conservative methods becomes deficient due to the population and the requirement for

power to keep increasing. Therefore, the wasted energy must be transformed into usable form using the PZT sensor [13]. This sensor can convert the pressure to voltage. Electricity has become a lifeline for the human population. Some technology needs enormous electrical power to perform various operations. This project used a microcontroller to measure battery voltage and display the status of the sensor and battery voltage in LCD. Capacitors are used to filter the output from the series connection of the PZT sensor before sending it to the unidirectional current controller. A diode is used as a unidirectional current controller to enable the current flow in just one direction.

According to Sulochana, S. (2019), a PZT plate is a device that detects pressure, acceleration, strain, or force by converting them to an electric charge via the PZT effect. This project developed a project using the combination of a PZT sensor and a Peltier sensor. PZT sensors operate when the source of pressure is from the weight of the moving vehicles or the weight of people walking over it while Peltier is used for transferring the heat produced by PZT to energy as well. The output of the bridge circuit is not constant, so that, a bridge rectifier is used to convert the fluctuating voltage into a linear value. In addition, it also used AC ripple to filter the fluctuations in output. Then, the output voltage is stored in a battery to provide provision to connect the AC load [14]. The voltage produced across the tile can be seen in an LCD by connecting it with a microcontroller AT89S52.

Dalabeih, D. et al (2018) research paper is on seeing the feasibility of installing the tiles in the university hallway. This project used 35 units connected in series-parallel which have 5 columns in parallel and 5 columns in series to provide high current and voltage respectively [15]. This experimental model used the energy harvesting circuit LTC3588 to light up an LED lamp at 1.8V and simulate energy storage by connecting it to a small storage battery [15]. The output voltage was measured and analyzed by using the oscilloscope. Based on this research paper, the minimum output voltage is 14V from 50kg of student weight and the maximum is 52.5V from 105kg of student weight.

3.0 MATERIALS AND METHOD

The development of floor tile power-generating light-up LED is divided into two parts which are hardware and software. Both parts will be discussed in this section.

3.1 Hardware

3.1.1 Arduino Uno

Figure 1 shows the Arduino Uno controller. Arduino Uno is an 8-bit Atmega328 microcontroller-based microcontroller board. It has a USB interface, 14 digital I/O

ports, and 6 analog input pins that can be connected to an external circuit. The code is transferred to the controller by utilizing Integrated Development Environment (IDE) software and most likely C and C++ language is used. Arduino Uno has a specialty where it is compatible with all computer systems such as Windows, Mac, or Linux Systems. Arduino board also has built-in voltage regulation where it can control the voltage even if it is connected to the external power source.



Figure 1: Arduino Uno

3.1.2 Piezoelectric Sensor

Figure 2 shows a PZT sensor. A PZT sensor is rigid and required only a small deflection of the material to get a usable output signal. It is used to measure or generate electricity caused by applying mechanical force. The applied force, pressure, strain, or strain is directly proportional to the voltage at the source and filter network. It can measure the conversion of energy into electrical charge but in this project, it is focusing on the pressure and force. The applied mechanical tension is related to the output signal.



Figure 2: Piezoelectric Sensor

3.1.3 Buck-boost Converter

Figure 3 shows a buck-boost converter. Buck-boost is a type of switching power supply that combines the step-up and step-down principle in a circuit. Buck produces a DC output with a very small input voltage and a boost converter will produce an output that is higher than the input voltage. This equipment is used based on its function as output from a PZT sensor is not stable and stable output required a certain amount of voltage to charge the battery.



Figure 3: Buck-Boost Converter

3.1.4 Charge Controller

Figure 4 shows the charge controller used in this project. The charge controller is a component to regulate the voltage and current that are added to the battery. It will prevent the battery from overcharging and overvoltage which will cause a decrease in the battery performance and lifespan. It is also used for protecting the power from flowing backward which may cause harm to the circuit.



Figure 4: Charge Controller

3.1.5 ESP8266-01 Module

Figure 5 shows the ESP8266-01 module. ESP8266-01 is a Wi-Fi module that contains a System On Chip (SOC) with an integrated Transmission Control Protocol / Internet Protocol (TCP/IP) stack that can give any microcontroller access to Wireless Fidelity (Wi-Fi) network. Each SP8266-01 module comes pre-programmed with an Attention Commands (AT) set firmware. It allowed this device to be integrated with the sensor and other application-specific devices through its General Purpose Input/Output (GPIOs). In this project, it is used to connect Arduino Uno and Blynk applications. The output produces by the sensor sends the data to the Blynk application.



Figure 5: ESP8266-01 Module

3.2 SOFTWARE

3.2.1 Blynk Application

Figure 6 shows the Blynk application used as an application that keeps the data of the project. Blynk application is an application editor platform for creating projects based on the Internet of Things. It also contains a Blynk server that allows all the communications between the smartphone and hardware. It can control hardware remotely, display sensor data, store data, visualize, and many more.



Figure 6: Blynk Application

3.2.2 Arduino IDE

Figure 7 shows the Arduino Integrated Development Environment (IDE) software logo used for writing the programming code of Arduino Uno. Arduino IDE is a free software that lets interference with an Arduino controller. Arduino IDE is an open-source Arduino software coding compiler to be uploaded to the Arduino board. It is compatible with all types of Arduino and is the only software that allowed the communication in Arduino controller.

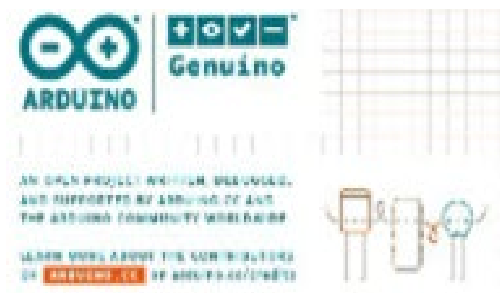

Figure 7: Arduino IDE Software

3.3 METHOD

3.3.1 Block Diagram

A block diagram of a Light light-emitting diode (LED) floor tile power generator is shown in Fig. 8. The project function is when someone steps on the floor tiles, pressure is applied to the sensor and causes a reaction from pressure into electricity. The bridge rectifier will convert AC output to DC. Then the buck-boost will increase the voltage input

for the battery to store the energy produced by footsteps. The charge controller in between the buck-boost converter and battery is to protect the battery from overcharging. Moreover, from the bridge rectifier, the PZT sensor is also directly connected with Arduino Uno to send the data of energy produced to the Blynk application. Lastly, from Arduino and ESP8266 it will send the signal to the LED lamp and Blynk application to display the voltage produced and light up the LED. The Arduino Uno uses external power sources to power up.

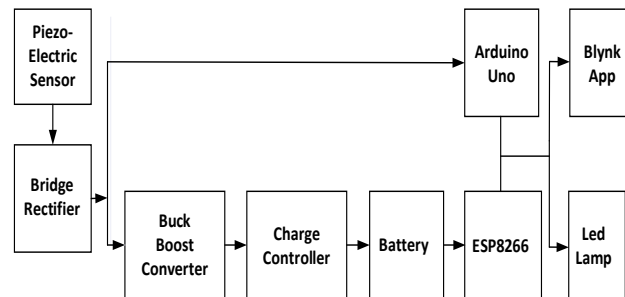

Figure 8: Block Diagram

3.3.2 Flow Chart

Figure 9 shows the process flow of the project. This project starts when pressure is applied to the sensor, and it causes the sensor to trigger. Then the process continued to convert the AC pressure to DC. The Bridge rectifier will pass through a buck-boost converter to increase the voltage to charge up the battery as well as regulate the voltage to power up the Arduino controller. The charge controller is used to protect the battery from overcharging. Next, the Arduino controller will send the signal to trigger the LED lamp and the Blynk application to send data via Wi-Fi. However, if there is no pressure applied, it will use power from the battery source to light up the LED lamp using the Blynk application.

4.0 RESULT AND DISCUSSIONS

4.1 Result 1: Number of Piezoelectric Sensors

Table 1 above shows the result obtained from connecting the PZT disc in series, parallel, series-parallel, and single PZT discs. Based on the results, it can be seen that one PZT disc can produce about 0.549V and 0.001mA. Then when two PZT discs in parallel, the voltage remains the same, but the current is increased to 0.003mA while in series, the voltage increases to 1.1V and the current maintains 0.001mA. In addition, in a series-parallel connection, the voltage increases drastically to 1.519V and the current at 0.010mA. However, the current in a series-parallel connection is still small because PZT sensors produce small output. Next, the value in multimeter is the slightly different as in the Blynk Application due to the voltage drop in the bridge rectifier circuit. Blynk

Application can only monitor the voltage but not the current because the circuit does not have a current sensor which is the reason measured current using a multimeter.

Table 1: Output Results from Piezo Testing Connection

Number of piezo sensors	Connection	Voltage		Current (mA)
		Multimeter	Blynk Application	
1	Single	0.549	0.499	0.001
2	Parallel	0.549	0.504	0.003
2	Series	1.120	1.1017	0.001
2	Series-Parallel	1.519	1.477	0.010

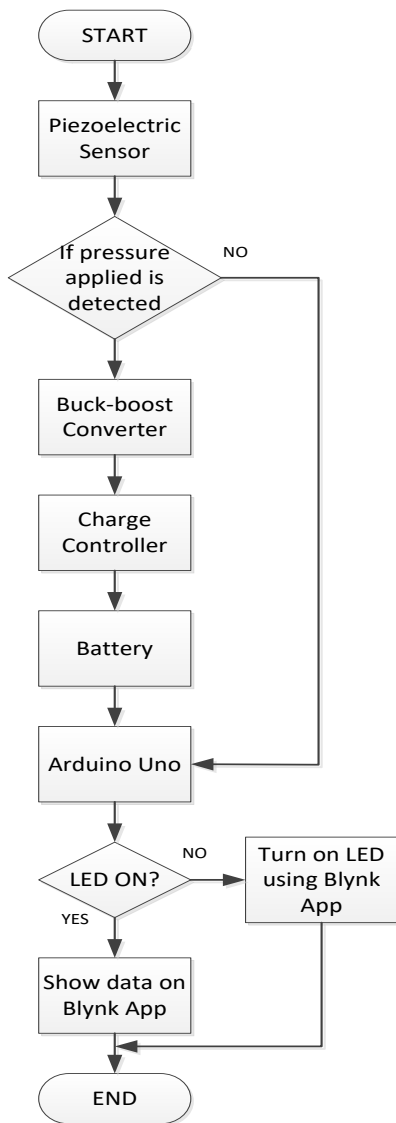

Figure 9: Flow Chart of the Project

4.2 Result 2: Output result in Different weights Applied on Floor Tile

Table 2 shows the results obtained from different weights applied on the floor tile. The PZT sensor is connected in a series-parallel to balance the output voltage and current. Based on the results it shows the data was collected in seven different weights which are 11 kg, 26 kg, 35 kg, 42 kg, 53 kg, 58 kg, and 70 kg. The highest output voltage is 70 kg where it produces 7.11 V and a current of 19.0 μ A after the PZT sensor connects with the bridge rectifier, then it increases to 16.81 V and 41.1 μ A after the boost converter and LED light up. The lowest output voltage is 11 kg where it produces only 1.33 V and 4.1 μ A after the PZT sensor connects with the bridge rectifier. Due to its lower output value, the boost converter does not trigger, causing the LED off and no power produced to store in the battery. The same case happens in 26 kg of people's weight. The boost converter is triggered when the minimum voltage is 3 V. LED lamp will light up when 35 kg, 42 kg, 53 kg, 58 kg, and 70 kg people weigh because the input voltage to the boost converter is above 3 V. Fig. 10 shows the sample of output voltage display in Blynk application.

Table 2: Output Results in Different Weights Applied on Floor Tile

Weight (kg)	Bridge rectifier		Boost converter		LED
	Voltage (V)	Current (μ A)	Voltage (V)	Current (μ A)	
11	1.33	4.1	0	0	OFF
26	2.18	7.7	0	0	OFF
35	3.58	9.2	5.7	14.4	ON
42	4.74	13.7	8.97	15.9	ON
53	5.07	14.7	10.3	26.4	ON
58	6.03	15.5	11.2	30.3	ON
70	7.11	19.0	16.81	41.1	ON

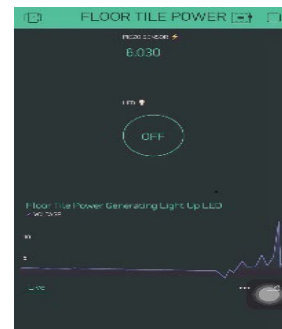

Figure 10: Output Voltage Display in Blynk Application

Next, Fig. 11 shows the comparison results for the voltage output measurement with the Blynk Application for each different PZT connection. These results show the same and do not deviate much from each other.

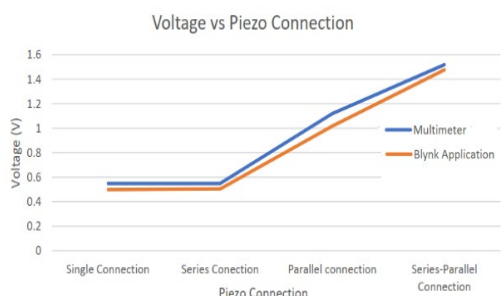

Figure 11: The Comparison of Output Voltage between Multimeter and Blynk Application with different connection Piezoelectric

4.3 Control LED via the Blynk application

The light control test is carried out by tapping the ON or OFF button widget on the Blynk application on the smartphone. The lamp can be controlled via the Blynk application after the system is connected to Wi-Fi. However, if the internet connection is poor, it will affect system performance by causing the LED lamp not to light up or a bit of delay to light up. The left side of Fig. 12 shows the widget button on the Blynk application, and the right side shows the led function accordingly when the internet line is in good condition. The purpose of controlling the LED light-up is to use the led lamp when it is necessary for example when it is installed in a street and needs to light up the streetlights at night. The LED lamp will use the power produced by the PZT sensor stored in the battery.

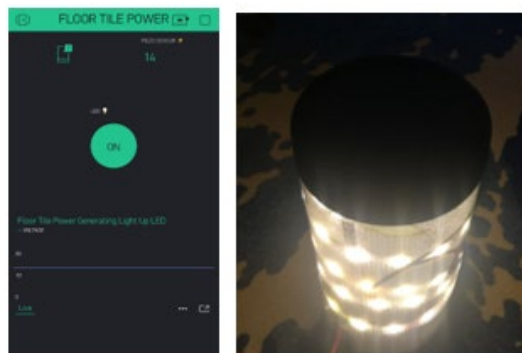

Figure 12: Blynk Application Control LED

5.0 CONCLUSION

The development of Floor Tile Power Generating Light Up LED proposes a method for generating clean and off-grid energy in providing the addition of solving the problem of the decreasing issue of fossil fuels. Even if the output is small, it still can generate energy and can be used in a small power required like street lighting, lighting of pavement side buildings, and public charging ports. This may not completely overcome the energy crisis however it can

reduce the dependency on energy usage and give the benefit to people in terms of health because it encourages people to walk in that area to help generate the energy.

Furthermore, based on the analysis conveyed, it can be concluded that the project development is achieved the objective. The project function accordingly, which is to develop a floor tile that generates power by using the energy harvesting system, analyzing its output value, and collecting the data then send to a smartphone. The first objective is achieved as it successfully functions as planned even if there is a slight error where it can detect even the smallest pressure of the rubber stopper. Then the second objective is achieved as shown in Table 2. The output value is analyzed based on people's weight. Heavy people produce more output compared to people that have lightweight because the pressure applied is more.

In addition, the third object achieved when the voltage produced can be displayed in the Blynk application via smartphone. The PZT sensor shows that it is not practical to use it in a large output power needed but it can be used in a small output power required. The floor tile can be installed in a crowded area to increase its output power. A volume analysis can be performed to quantitatively evaluate the PZT power harvested in a given area considering the number of pedestrians passing through per unit time. The PZT sensor shows it can convert mechanical energy which is presumed to be daily wasted energy into harvested electrical energy.

6.0 RECOMMENDATION

The research and study that has been undertaken for this thesis have highlighted several topics on which further improvement would be beneficial. The following recommendations for future study are hereby made:

- Add a system that can operate on both conditions which are via Wi-Fi and Bluetooth because some of the places do not have a good internet connection. So that it is easier for the user to see the data and control the LED light. The user can turn on the LED light by itself if they want to use it.
- Use a bouncy technique like a spring floor system to create more pressure. In bouncy tile, it will apply uniform pressure to all sensors. So, it will create higher output and reduce stress on the PZT sensor.
- Add a weight sensor to see how much voltage can be produced based on a person's weight scale. This weight sensor data can be sent through the Blynk application as well. Thus, it makes this device provide two functions which are generating energy and body weight scale.
- Add a voltage and current sensor to make it easy to detect the voltage and current produced by the floor tile.

REFERENCES

- [1] Poddar, S., Dutta, M., Chowdhury, D., Dey, A., & Maji, D., "Footstep Voltage Generator using Piezo-Electric Transducers," Article from International Journal of Science & Engineering Research, Vol. 8, 2017. Available: <https://www.ijser.org/researchpaper/Footstep-Voltage-Generator-using-Piezo-Electric-Transducers.pdf>.
- [2] Niveditha M.B., Dharani L., Jithendra V., Ravichandra D.P. & Sheila H., "Electrical Power Generation Using Footsteps," Article from International Journal of Innovative Research In Technology, 2020. Available: https://ijirt.org/master/publishedpaper/IJIRT149780_PAPER.pdf.
- [3] Putri Norlyana Mustafa Kamal & Buniyamin, N., "Using PZT Elements as Footsteps Energy Harvester: An Investigation," Article from International Conference on System Engineering and Technology (ICSET), 2018. Available: <https://www.semanticscholar.org/paper/Using-Piezoelectric-Elements-as-Footsteps-Energy-an-Kamal-Buniyamin/757ebcb71e456b091a48133ab389bd0e2f3a1db8>.
- [4] Bojja, P., Nakirekanti, M. & Krishna, M.G., "Foot Steps based Energy System for Street Lights," Article from International Journal of Computer Applications, Vol. 112, 2015. Available: <https://citeseerx.ist.psu.edu/viewdoc/download?doi=10.1.1.695.3936&rep=rep1&type=pdf>.
- [5] Abadi, P.B., Darlis, D. & Sarwoko, M., "Green energy harvesting from human footsteps," Article from MATEC Web of Conferences, 2018. Available: https://www.researchgate.net/publication/327599775_Green_energy_harvesting_from_human_footsteps.
- [6] Mota, J.B., Nayyar, D., Oza, N. & Shetye, Y., "Pedestrian detection & locomotion tracking using piezoelectricity & MATLAB," Article from International Journal for Scientific Research & Development, 2018. Available: <http://www.ijserd.com/articles/IJSRDV6I70343.pdf>.
- [7] Vinyak, M. N., Laxman, S. A., Shashikant, G. S. & Dinkar, Y. P., "Foot Step Power Generation using Piezoelectric Material," Article from International Journal for Scientific Research & Development, Vol. 3, 2016. Available: <https://pdfcoffee.com/footstep-power-generation-using-piezoelectric-material-pdf-free.html>.
- [8] Srivastava, R., Tiwari, N., Kumar, A. & Sen, D., "Power Generation Using Piezoelectric Material," Article from International Advanced Research Journal in Science, Engineering, and Technology, Vol. 2, 2015. Available: <https://iarjset.com/upload/2015/si/ncree-15/IARJSET%2026%20P130.pdf>.
- [9] Mugali, S., Bindu, G., Chilukuri, S., Deepthi, G. & Kavya, B., "Footstep Power Generation Using Piezo Electric Transducers," Article from International Journal of Latest Technology in Engineering, Management & Applied Science, Vol. 7, 2018. Available: <https://www.ijltemas.in/DigitalLibrary/Vol.7Issue5/166-169.pdf>.
- [10] Raju, K., Theja, B., & Rao, R., "Arduino Power Generating Using Human Foot Step," Article from Journal of Engineering Science, Vol. 11, 2020. Available: <https://jespublication.com/upload/2020-1104153.pdf>.
- [11] Ali, A., Khan, U. Ahmad, M. O., Aziz, A. & Neha, "Footstep Power Generation Using Piezoelectric Sensor," Article from School of Engineering Science and Technology, 2020. Available: <https://eudl.eu/pdf/10.4108/eai.27-2-2020.2303209>.
- [12] Sahoo, G., Divekar, N. & Rao, R., "Smart Street Lighting Using Piezoelectricity," Article from International Journal of Advanced Research in Electrical, Electronics and Instrumentation Engineering, Vol 5, 2016. Available: https://www.ijareeic.com/upload/2016/july/32_SMART.pdf.
- [13] Chavan, A., Lakhadive, S., Pondhe, V. & Prof. Philip, V., "Advanced Foot Step Power Generation Using Piezo-Electric Sensors," Article from International Journal of Advanced Research, Ideas and Innovations in Technology, Vol 3, 2017. Available: <https://www.ijariit.com/manuscripts/v3i3/V3I3-1172.pdf>.
- [14] Sulochana, S., "Generation of Power Using Piezoelectric and Heat Sensor," Article from International Journal of Current Engineering and Scientific Research, Vol 6, 2019. Available: <http://troindia.in/journal/ijcesr/vol6iss1/36-40.pdf>.
- [15] Dalabeih, D., Haws, B. & Muhtaseb, S., "Harvesting Kinetic Energy of Footsteps on Specially Designed Floor Tiles," Article from International Renewable Energy Congress, Vol 9, 2018. Available: <https://ieeexplore.ieee.org/document/8362566>.