

# Design and Implementation of Solar Tracking System Using LDR Sensor

Ahmad Zaqirin Hasan<sup>1</sup>, Mohd Izhar A Bakar<sup>2</sup>

<sup>1,2</sup>Section of Electrical Technology  
University Kuala Lumpur British Malaysian Institute  
Batu 8, Jalan Sungai Pusu  
53100 Gombak Selangor, Malaysia.

Corresponding email: [mizhar@unikl.edu.my](mailto:mizhar@unikl.edu.my)

**Abstract:** Solar technology has been widely used nowadays because the source of sunlight can be converted into electricity and used by humans on the surface of the earth. The National Energy Policy (NEB) acknowledges the increase in oil prices in 2015 and the global electricity crisis adversely affecting Malaysia, which is solely dependent on oil. In general, when harvesting solar energy can be done, another challenge that will be faced is the inefficiency of solar panel arrays, and insufficient sunlight sources due to weather factors to generate more electricity. To solve this problem, another approach is to build an automatic system that consists of solar panel tracking, Light Dependent Resistors (LDRs), microcontrollers, and servo motors that are used to detect sunlight throughout the day to allow the system to generate maximum electricity. It was found that the voltage output from the solar panel detection approach is higher when compared to the horizontal method which is a fixed solar panel. Therefore, the output generated from the built system will be distributed to the rural population for daily use.

**Keywords:** Tracking System, Light Dependent Resistors, Microcontrollers, Servo Motor

## 1.0 INTRODUCTION

The main purpose of this project is to find a solution to improve the performance of solar array panels by using solar trackers. The most important part of this project is the tracking mechanism that allows the movement and position of the solar array to increase the power output and reduce the losses in terms of cost. Electricity is a much-needed energy in any developing country in the world. From existing statistics as much as 85% of energy is taken from fossil sources. The effects of excessive use of fossil fuels will cause the world to heat up rapidly due to the release of gases into the atmosphere. Other sources such as solar, wind, and Biomass are still not popular in producing electricity in Malaysia. In the past five years ago, Malaysia has made strides in popularizing solar energy converted into electricity by using solar panels or Photovoltaic (PV) as shown in Fig. 1

The solar efficiency of this panel will exceed 24% if the position of the solar panel is high place. Not all solar panels can be placed in high locations due to geographical problems and installation costs. Therefore, solar tracking panels are recommended to track sunlight from sunrise to

sunset. The solar panel tracking model is shown in Fig.2 to illustrate the operation of solar panel tracking.

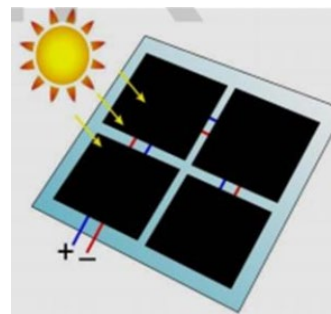

Figure 1: Solar Panel

Based on this approach, it was found that solar panel efficiency can be optimized to 30% to 60% to generate electricity. Many parts will be used in designing the solar tracking systems such as LDR sensor, Microcontroller, and servo motor compared with the conventional approach, which is horizontal solar panels in a fixed state. Through this system, the solar panel will track the sunlight automatically throughout the day to produce more output voltage.

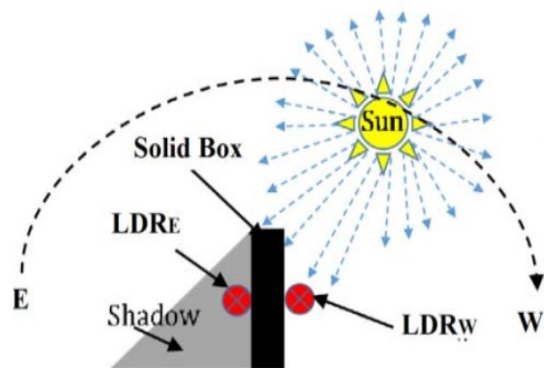

Figure 2: Solar Tracking System Model

With the development of this system, this system can be installed in rural areas that do not have enough electricity. In general, solar panels that are placed permanently cannot generate much power because solar panels do not receive the full amount of sunlight compared to tracking solar panels.

## 2.0 PREVIOUS STUDIES

In this section, a summary of the scientific study from the main reference is explained below.

### 2.1 A Prototype Solar Tracking System Design And Implementation

This paper has described the experimental results for solar detector panels compared to fixed panels using micro control and LDR. The experimental readings were taken in different weather and days. Experimental results show that the efficiency of the detection system is better than the fixed system by 12.3% on sunny days and 4.9% on partly cloudy days. Unfortunately, there is a sharp drop in readings during cloudy weather. In terms of the total power output during clear weather, the total power output through solar tracking is more than 10.96% of the fixed system. The reading for total power output on a cloudy day is 4.63% higher than a regular system. Meanwhile, for cloudy days, the total power output is 3.4% less than the regular system. Therefore, the developed system is suitable for detecting sunlight in generating electricity. All the works were based on hardware where the circuits consist of microcontroller Arduino and LDR [1].

### 2.2 Design and Implementation of Solar Tracking System using LDR Sensor

This paper presents solar energy as one of the renewable energy sources that can produce electricity. Solar energy conversion is better than others because of its clean, silent, and reliable features, which require low maintenance costs. One way to increase their efficiency is to maximize the capture of sunlight on solar panels, to

increase power output. Solar tracking methods can increase the electricity production of PV systems. The approach in the design of this system consists of an automatic dual-axis solar detector connected to a mechanical structure with a controller, a DC motor, and an LDR. The controller can be done with an Arduino Uno, a DC motor to move the solar panel up and down, and an LDR sensor to detect the presence of light. For this purpose, a complete circuit will be developed and fully operational to produce more electricity based on the correct position of the sun.

This paper shows that the voltage output from the system gradually increases to a maximum between 11.00 am and 1.00 pm. The output voltage reading at that time was between 10.9V to 11.9V. Next, the output voltage drops significantly from 11.8V to 1.5V from 2.00 pm to 6.00 pm due to less sunlight [2].

## 2.3 Automatic Solar Tracking System

This paper describes the design and construction of a microcontroller-based solar panel detection system. Solar is a non-conventional source of energy. Experiments have been done to generate electricity from solar sources. But due to the revolution of the earth's solar resources, for example, the sun cannot face the panel continuously, so the effect is that less energy is produced. This problem can be solved by using a system to detect solar energy automatically. The system will be connected to the LDR sensor to detect the maximum solar power and fed to the Microcontroller through the ADC. Next, the controller will act according to the algorithm as set before. The inclination of the solar tracker of the panel towards maximum energy depends on the response of the LDR with the help of a DC Motor.

The system can track and follow sunlight intensity to collect maximum solar power regardless of motor speed. The uniqueness of this system is developed by using the motor speed, but it is not the most critical thing because the DC motor offers low speed and high torque output. Therefore, any type of DC motor can be used for this system regardless of the motor speed controller unit as long as the speed and torque of the motor are according to the given specifications. The built system model can be applied in residential areas for alternative electricity generation, especially for non-critical and low-power equipment [3].

## 2.4 A Smart Control Based On Microcontroller For Solar Tracking System

This paper describes an approach to the development of a system to obtain better electricity to reduce dependence on the use of fossil fuels. This approach uses an AT-MAGA328P control, a servo motor, and an LDR

sensor. The AT-MAGA328P microcontroller is used to control the movement of the two-axis solar panel through the use of servo motors. Solar energy is an important source of energy production at a lower cost and potentially clean because solar cells depend on the intensity of light and the angle of radiation emitted by the sun's rays due to the Earth's rotation. Therefore, the system that needs to be developed can ensure that the best sunlight is perpendicular to the solar cell, which is the focus of research to create a smart, low-cost, and efficient system.

In addition, this paper shows that in the early morning that is sunrise the response of the system will vary according to the light intensity where the motor movement is less during the day at high light intensity and thus increases efficiency, and production. low-cost electricity. The results also show clear results with solar tracking systems compared to fixed solar systems or traditional methods [4].

### 2.5 Active Solar Tracking System Using Node MCU

This paper describes the design and implementation of an automatic single-axis active solar tracking system. The realized prototype uses Node MCU ESP 8266. The ESP8266 module is used as the controller. This prototype system can be used as an alternative power generation source using high-power solar panels. In the experiment, a 5-watt solar panel was used. Different data sets were logged using the tracker on sunny days, cloudy days, etc. Further, this work is extended for a dual-axis solar tracker with additional IoT functionality. With IoT systems, the entire system can be monitored remotely. Solar tracking can be classified into three parts namely:

- a. Active solar tracker, the sensor is controlled by the controller to track the path of the sun and absorb the maximum amount of sunlight. They can be categorized into single-axis solar trackers and dual-axis solar trackers.
- b. Passive solar trackers, solar trackers that depend on the rotation of the earth with different geographical locations.
- c. Single-axis and dual-axis trackers depend on the axis of rotation. Some tests have been carried out by designing a dual-axis solar tracker based on Arduino.

This paper also discusses the earth phenomenon that causes day and night. Seasonal changes also play an important role in determining the amount of sunlight intercepted by the Earth. Another thing that is taken into account in determining the correct position of the sun is the Zenith angle and Azimuth. The zenith angle is the same as the elevation angle, while the azimuth angle is the angle between the south and the horizon point when the sun is

directly below the sun. Fig. 3 shows the zenith angle and azimuth [5].

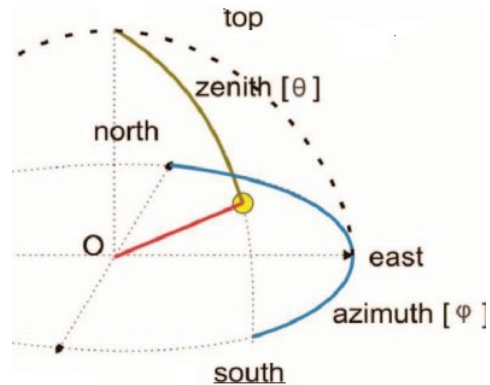

Figure 3: Zenith and Azimuth Angle [5]

### 2.6 Implementation of Dual Axis Solar Tracking System

An automatic solar detector system based on an Arduino prototype was built using an Arduino Microcontroller, four LDRs, and three stepper motors. Combined with hardware and programming firmware can run the system. Four LDR are used to capture light to maximize the efficiency of the hardware. The LDR and stepper motor move in various directions to follow the intensity of sunlight. Meanwhile, the vertical tilt and horizontal rotation of the solar panel will be controlled by a microcontroller. With the compatibility of circuits, the solar panel will follow the direction of the sun, not only vertical rotation but also horizontal rotation. Therefore, the system can capture the maximum amount of sunlight, thus reducing the cost of energy generation as well as reducing the number of solar panels used. Fig. 4 shows the power output of the solar tracker is improved compared to the traditional fixed PV network as well as improves the system performance.

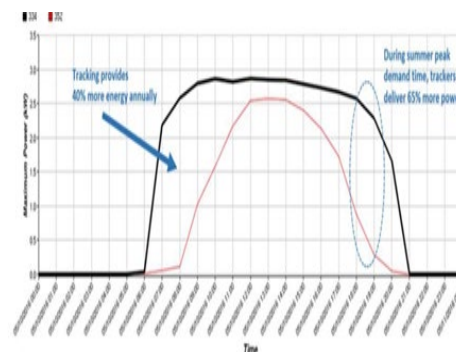

Figure 4: The Performance Graph System [6]

In general, the maximum solar energy cannot be tracked by using solar fixed only, therefore it needs another axis to capture more sunlight. The system performance

shows that solar tracking contributes 30-40% more than fixed solar panels which is 6-7%.

In addition to using Arduino, it can also be added to the Internet of Things so that data can be stored in the cloud for the latest information and track the exact position of the sun [6].

### 2.7 Simple Design and Implementation of Solar Tracking System Two Axis with Four Sensors for Bagdad City

This paper has described the project in designing and implementing a solar detection system using two axes: the azimuth angle and the elevation angle, using LDR by the actual dimensions of the project. The project was compared with a fixed solar panel. The results showed that the solar tracker had more output power than the fixed solar panel. The project is divided into two parts: hardware and electronics. The hardware parts are integrated into a solar panel, two DC motors with a gearbox, and an LDR sensor module. The second part is the electronic circuit. Meanwhile, the implementation is divided into two stages. First stage: Direct sensing is done through a set of LDR sensors as output tuning to trim azimuth and elevation angles. The second stage is to monitor the system performance by looking at the voltage output during cloudy, dusty, or rainy weather, the tracking system will stop so that the system remains in the position of the sun without moving based on Kelly's Cosine theory of power. The energy extracted from PV is represented in Fig. 5.

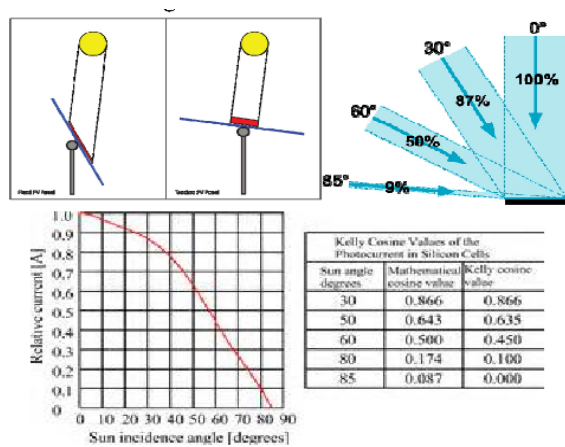

Figure 5: Kelly Cosine Values Relationship [7]

Furthermore, this paper can provide an overview of the mechanism of solar tracking to increase solar energy acquisition, solar tracker operation cost, and relatively low maintenance cost. The design and implementation of solar detection using the above method are very effective in determining the intensity of sunlight falling. The results show that the solar tracking system is more effective than

fixed solar panels which is 35% compared with fixed solar panels. In analyzing the data, the energy obtained from the solar tracker is high throughout the day from morning to evening and appears to be higher during peak sunlight. If, compared solar panels are still only efficient in peak sun conditions [7].

### 2.8 Solar Tracking System

This paper describes the effects of global warming on the earth and can use energy as electricity to operate electrical equipment. One of the approaches is to convert sunlight into electricity by using solar panels. Most of the solar panels that have been installed by users are only in one direction. If the solar panel is located in the east and the sun is located in the west, the solar panel cannot be charged. Therefore, in the presence of other alternatives, battery charging can be done efficiently, and the generated voltage will continue. The system to be developed is a solar detection system. This solar detection system uses an AVR-Atmega16 microcontroller as the brain to control the entire system assisted by LDR to detect the light intensity at 30 degrees every hour and rotates completely by 180 degrees as shown in Fig. 6 compared to the old system panels solar cannot rotate. Then, the signal from the LDR is sent to the AVR-Atmega16 microcontroller. This AVR-Atmega16 microcontroller will compare the data and rotate the servo motor to the right, center, and left. The servomotor rotates the solar panel based on the highest light intensity and displays the output voltage on the Liquid Crystal Display (LCD). This system is suitable for use in homes or small factories that want to reduce electricity bills in the long term.

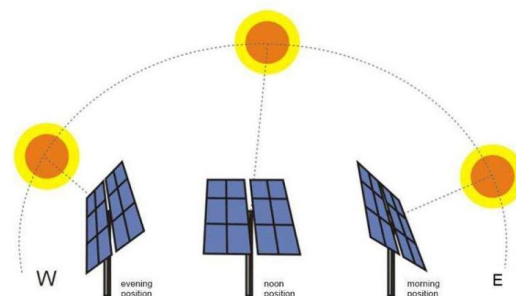

Figure 6: Solar Tracking System [8]

In general, this system uses the concept of solar tracking from sunrise to sunset. Therefore, the sun is always tracked and thus able to maintain the vertical flow of sunlight. Then increase the efficiency of solar panels to generate electricity [8]. A comparison between tracking and fixed solar panels is tabulated in Table 1.

Table 1: Comparison Of Solar Tracking Systems and Previous Types Of Fixed Solar Systems.

Parameter	Solar Tracking System	Previous Type of Solar System
Type of circuit	Simple	Complex
Direction of sensor	30 degree from east to west (180 degree total)	45 degree from east or 45 degree from west
Output power	High	Low
Type of microcontroller	AVR (atmega16)	Intel8051

Besides that, this paper discusses the advantages and disadvantages of this system as tabulated in Table 2.

Table 2: Advantages and Disadvantages of Solar Tracking System

Benefit	Disadvantages
The use of manpower is reduced	A little expensive
Save Power	Complex design
Easy installation	Depends on the climate
Improve system efficiency	
Low maintenance	

### 3.0 METHODOLOGY AND MATERIALS

This section explains the concepts of block diagrams, flowcharts, and circuits developed in this project.

#### 3.1 Block Diagram

Figure 7 shows the block diagram of a dual-axis automatic solar tracker having four LDR sensors, two servo motors and connected to an Arduino Uno that acts as a microcontroller. The output of these four LDR sensors will send feedback to the microcontroller which moves the servo motor with the solar panel in the direction of the movement of the sun to get the maximum voltage output.

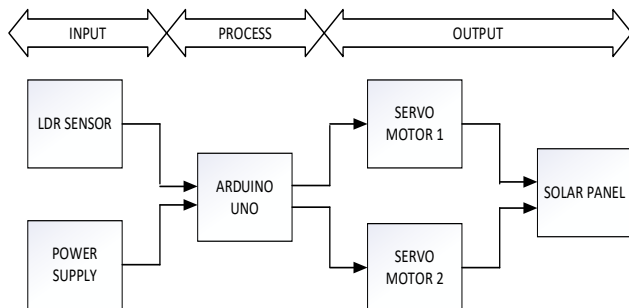

Figure 7: Block Diagram System

#### 3.2 Flow Chart

Figure 8 shows the flow chart used to describe the project. The main objective is to maximize the power output from the solar system with a dual-axis solar tracker. This system uses two servo motors. The first servo motor for 360 degrees i.e. horizontal direction. The second servo motor for 180 degrees which is the vertical direction that is parallel to the solar position.

The movement of the servo motor also depends on the value of the LDR resistance of the sensor and sunlight. The LDR sensor value depends on the sunlight based on four directions namely north, south, east, and west. If the LDR sensor reading is higher by any of the four positions, the sensor will send a signal to the Arduino Uno as a microcontroller. Next, the microcontroller will send a signal to the servo motor to move toward the position of the sun. The flow chart above can show the process from beginning to end for the solar tracking system.

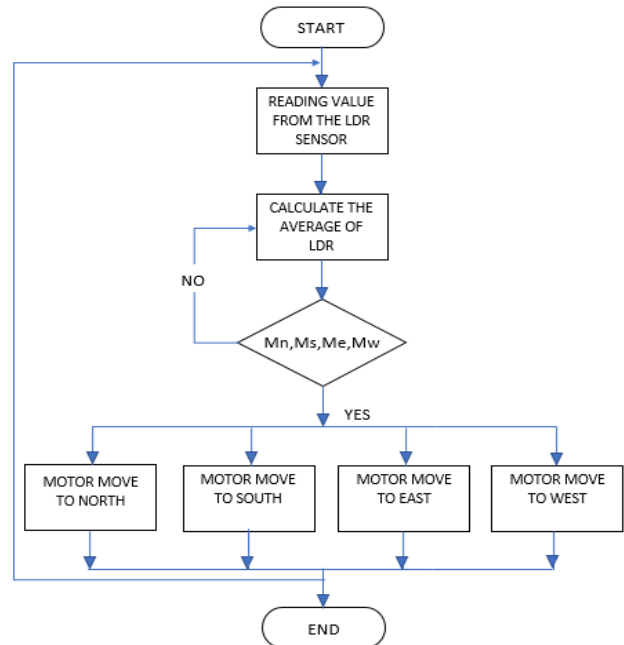

Figure 8: Flowchart System

#### 3.3 Circuit Diagram

Figure 9 shows a schematic diagram as well as significant circuit components, parts, and connections. Schematic diagrams are also used to calculate the costs involved in the project development. It is found that the cost to develop this project is small.

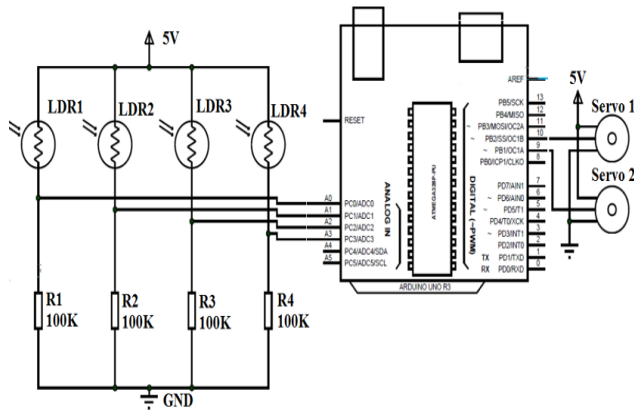

Figure 9: Schematic Diagram System

### 3.4 Hardware Implementation

The Arduino Uno is an Atmega-328-based microcontroller board shown in Fig. 10. In this project, the microcontroller acts as the brain that gives instructions based on the coding that is programmed into it. The board has 20 digital I/O pins (6 capable of Pulse Width Modulation (PWM) output), and 6 analog I/O pins, and is programmable with the Arduino Integrated Development Environment (IDE), via a type B USB cable. It can be powered by a USB cable or a barrel connector that accepts voltages between 7 and 20 volts, such as a rectangular 12V battery.



Figure 10: Arduino Uno

Figure 11 shows the LDR sensor is used as a solar detector during light and dark. For this solar detector, the operation of the LDR will detect the concentration of sunlight and then send a feedback signal to the analog port input of the microcontroller. Finally, this microcontroller produces a digital voltage output.



Figure 11: LDR

Solar energy can be used using Solar PV technology that converts sunlight into electricity. Also, solar PV is made of semiconductors shown in Fig. 12. When the solar panel is exposed to sunlight, it will start to produce voltage and current in the form of Direct Current (DC). The output voltage from the solar will be connected to the Inverter to produce Alternating Current (AC) and then fed to the electronic equipment.



Figure 12: Solar Photovoltaic

### 4.0 RESULTS AND DISCUSSION

This section shows the voltage and current results produced by the Solar Development System Detector that has been developed. The results produced by this system are controlled by using a servo motor mechanism. The first and second servo motors control the horizontal and vertical axes to obtain accurate sunlight observation assisted by the LDR microcontroller and Arduino UNO. Tables 3 and 4 show the reading results issued by the fixed panel and tracking

Table 3: Comparison of Output Voltage between Tracking Panel and Fixed Panel

Time of The Day	Voltage (V)		Difference (%)
	Fixed Panel	Tracking Panel	
8:00 am	1.15	2.09	44.98
9:00 am	1.89	2.82	32.98
10:00 am	2.17	3.48	37.64
11:00 am	3.52	4.76	26.05
12:00 pm	5.75	5.91	2.71
1:00 pm	6.68	7.48	10.70
2:00 pm	7.76	7.79	0.39
3:00 pm	7.56	7.67	1.43
4:00 pm	6.25	6.58	5.02
5:00 pm	4.49	4.69	4.26

Table 4: Comparison of Output Current between Tracking Panel and Fixed Panel

Time of The Day	Current (mA)		Difference (%)
	Fixed Panel	Tracking Panel	
8:00 am	11.1	13.2	15.91
9:00 am	13.7	15.1	9.27
10:00 am	21.7	26.7	18.73
11:00 am	32.4	38.7	16.28
12:00 pm	53.7	58.3	7.89
1:00 pm	65.3	69.2	5.64
2:00 pm	69.8	74.4	6.18
3:00 pm	59.3	62.7	5.42
4:00 pm	36.5	45.3	19.43
5:00 pm	21.3	27.8	23.38

The differences in results for solar and fixed tracking are shown in percentage values. This percentage value is relatively large in the morning because there is a significant adjustment of the solar detector panel automatically in determining the position of the solar detector in the right conditions to get a large amount of sunlight.

Figure 13 shows that the output voltage will vary according to the intensity of sunlight from 8.00 AM to 1.00 PM and 3.00 PM to 5.00 PM. It was found that the maximum output voltage for solar panel tracking and fixed is 7.79V and 7.76V respectively which is at 2.00 PM which is peak time. While the minimum output voltage from fixed and tracking solar panels is 4.69V and 4.49V occurs at 5.00 PM.

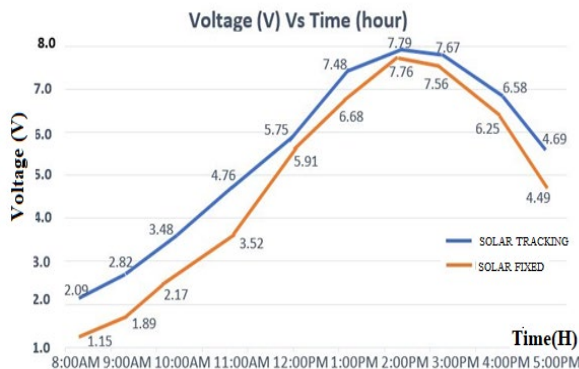

Figure 13: Comparisons of Output Voltage for Dual Axis and Fixed Panel in Voltage

At peak time, at 2.00 PM, the highest readings are 74.4mA and 69.8mA for solar tracking and fixed solar panels. This is because the tracking of the solar panel is

almost parallel to the sun compared to fixed solar. After all, the sunlight falls directly on the panel.

It was found that the output current increased from 11.00 pm to 2.00 pm and decreased in the afternoon. The lowest readings for fixed solar panels and detector solar panels were 21.3mA and 27.8mA occurred at 5.00 pm. The behavior for the rising and falling output current depending on the light intensity can be shown in Fig. 14.

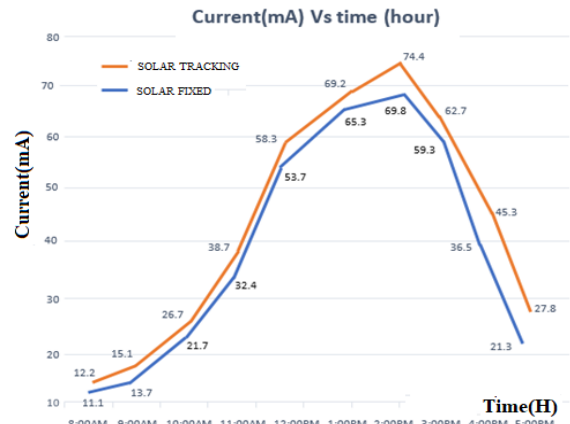

Figure 14: Comparison of Current Between Tracking Panel and Fixed Panel

Figure 15 represents the comparison of power yield between detector solar panels and fixed solar panels. A solar panel tracking system contributes more power than a fixed solar panel.

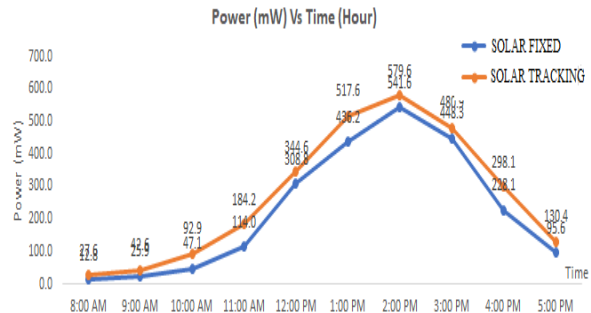
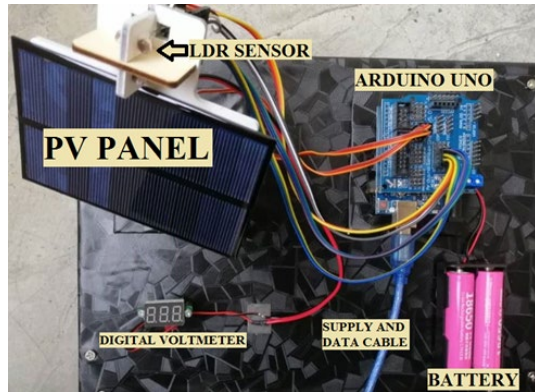
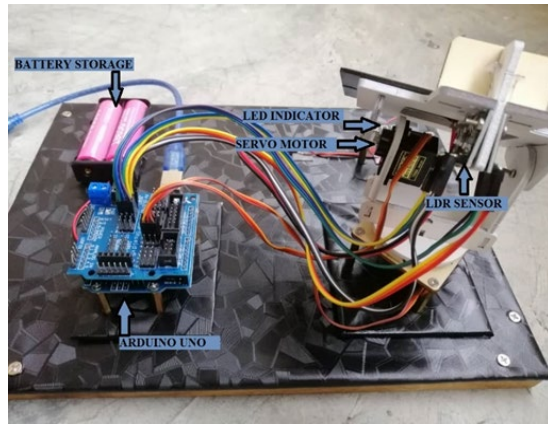

Figure 15: Comparison Of Power Output Between Detector Solar Panels And Fixed Solar Panels

A simple and low-cost prototype is illustrated in Fig. 16. This system can be installed in difficult areas to get the correct position of the sun such as on a hillside or flat land.



(a)



(b)

Figure 16: Prototype Project View (a) Top (b) Back

## 5.0 CONCLUSION

The average performance of solar panel tracking in contributing electricity is 45.1%. The results of the study also show that the solar panel tracking contributes a lot of electricity in the morning and evening because at noon time there is little difference and this proves that the fixed solar is efficient during noon time only. With this approach, it is shown that the solar panel tracking system is more efficient than fixed solar panels and can be installed anywhere.

## 6.0 RECOMMENDATION

The developed system model can be further improved as follows:

- a. Using a high-power servo motor to hold large-scale solar panels.
- b. Build an automatic circuit to turn off and on the power supply system at sunset and sunrise to save electricity.
- c. Using the Internet of Things (IoT) to monitor all the data from the solar panel to control the movement of the servo motor,

- d. Using image processing to recognize light density more effectively.

## REFERENCES

- [1] Faisal Ghazi Mohamed, "A Prototype Solar Tracking System Design And Implementation," *Journal of Kufa Physics* 12(01), pp. 32-37, 2020.
- [2] S.Sumathi, G.Gayathri, A.Jancy Rani, D. K. Karthikeyan, "Design and Implementation of Solar Tracking System Using LDR Sensor," *Int. J. Adv. Sci. Eng.* Vol.6, No.3, pp.1456-1461, 2020.
- [3] Nayana Raju, Lakshmi Priya K J, "Automatic Solar Tracking System," *GRD Journals, Global Research and Development Journal for Engineering, National Conference on Emerging Research Trend in Electrical and, Electronics Engineering (ERTE'19)*, May 2019.
- [4] Munther Mohammed Abdulhussein, Thaeer Mueen Sahib, Abed Al-Abbass Muhseen Jassem, Ali Abdyaseer Kadhim, "A Smart Control Based On Microcontroller For Solar Tracking System," *Solid State Technology*, Volume: 63, No: 6,2020.
- [5] Joysankha Ghosh, Naiwrita Dey, Pabak Das, "Active Solar Tracking System Using Node MCU," *International Conference on Computing, Power and Communication Technologies (GUCON)*. Sep 27-28, 2019.
- [6] V Mohanapriya, V Manimegalai, V Praveenkumar, and P Sakthivel, "Implementation of Dual Axis Solar Tracking System," *IOP Conf. Series: Materials Science and Engineering*, 2020.
- [7] Falah I. Mustafa, Sarmid Shakir, Faiz F. Mustafa, Athmar Thamer Naiyf, "Simple Design and Implementation of Solar Tracking System Two Axis with Four Sensors for Bagdad City," *The 9<sup>th</sup> International Renewable Energy Congress, IREC 2018*, 2018.
- [8] Vijjantee Wakchaure, Joel Jagtap, Lakshmi Priya B., "Solar Tracking System," *International Research Journal of Engineering and Technology*, 2019.